



# Model X2431 X-Tended Reach Grain Cart

Capacity: 875 bu • 23,8 t • 30,8 m<sup>3</sup>

Auger Diameter: 18 in • 45,7 cm | Unloads Rate: 400 bu/min • 11,9 t/min



## GREATER

Upward, Outward and Forward Reach



Storage Position



Field Position



Unload Position



### Drum Brakes



### ELECTRONIC WEIGH SCALE SYSTEM

Accurate to within ONE-HALF PERCENT, J&M's five point scale system features the Digi-Star GT400 indicator.

### Hydraulic Sliding Axle



80" or 203 cm  
117" or 3 m



120" or 305 cm  
156" or 4 m

J&M's hydraulic axle system extends for stability in the field, then contracts for narrow road transport.



DIMENSIONS		
	Standard	Metric
A	11'-2"	340 cm
B	9'-6"	290 cm
C	6'-8"	203 cm
D	8'-1"	246 cm
E	9'-10"	300 cm
F	10'-0"	305 cm
G	5'-0"	152 cm
H	19'-2"	584 cm
I	1'-7"	48 cm
J	20'-1"	612 cm
K	31'-0"	944 cm
L*	13'-4"	406 cm
M	9'-9"	297 cm
N	22'-0"	671 cm
O	12'-0"	366 cm
P	1'-6"	46 cm
Q	1'-4"	41 cm

## DIMENSIONS & SPECIFICATIONS

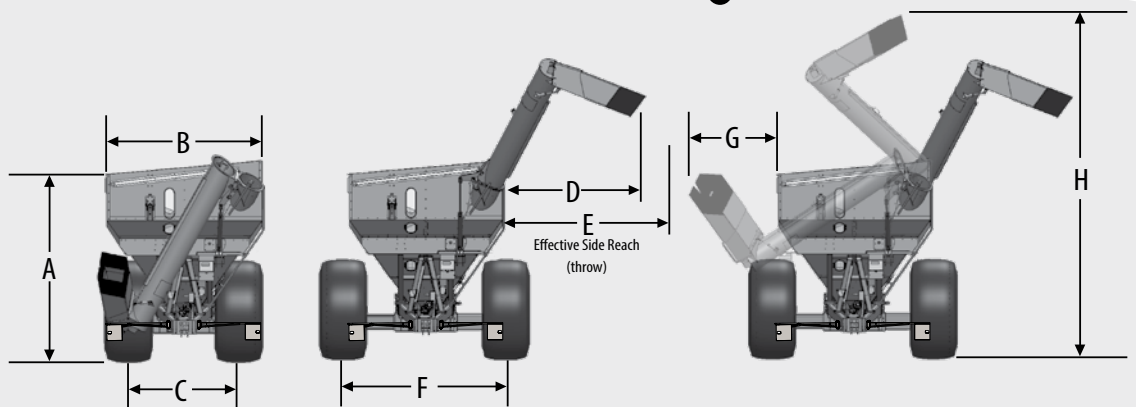

\*Measured at the center of the spout with all spout options installed

SPECIFICATIONS	Standard	Metric
<b>Capacity</b>	875 bu	24 t
<b>Auger, One Vertical</b>	18"	45,7 cm
<b>Unload Time (minutes)</b>	2.5 min	
<b>Wheels</b>	30x32	
<b>Tires</b>	900/60R32	
<b>Spindles (2)</b>	4 1/2" (no brakes)	11,4 cm (no brakes)
	5" (brakes)	12,7 cm (brakes)
<b>Tongue Weight</b>		
<b>Empty</b>	2,218 lbs.	1,006 kg
<b>Loaded</b>	3,968 lbs.	1,800 kg
<b>Total Weight (approx.)</b>	14,004 lbs.	6,352 kg

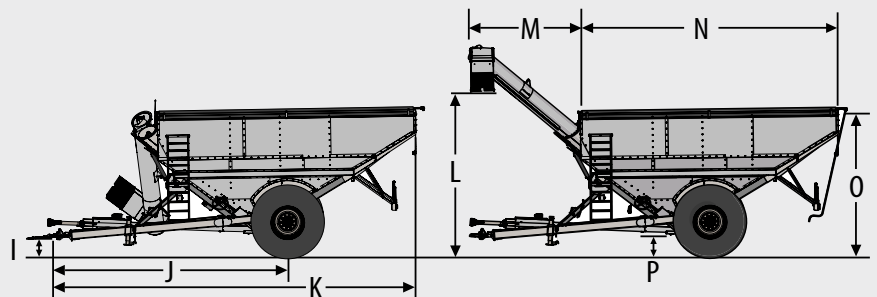

**J&M MANUFACTURING CO, INC**